

# THE ARCHERS OF CALEDON

## Outdoor Target Butt Stand Plans

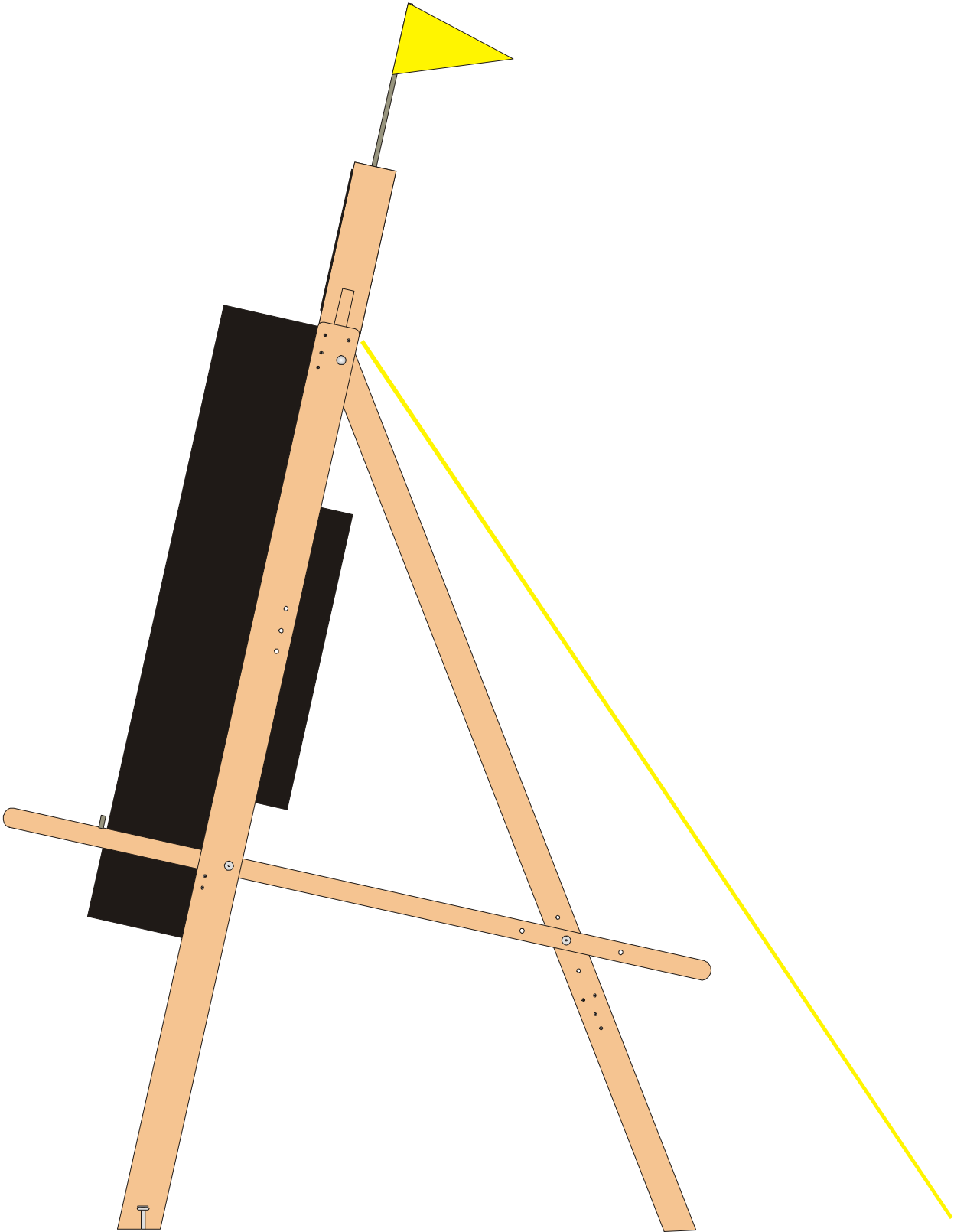

# TAOC Outdoor Target Butt Stand

The The Archers of Caledon Outdoor Target Butt Stand was design, built and used for the 2004 Canadian Target Championships. They were designed for use with American Whitetail 172c Ballistomatt (52") target mat. As numerous people have requested copies of these plans we are making them available on the TAOC Web site [www.archersofcaledon.org](http://www.archersofcaledon.org).

## Materials List

Wood		
Material	Dimensions	Quantity
pressure treated or cedar deck board	5/4" x 6" x 8'	2
pressure treated or cedar deck board	5/4" x 6" x 10'	1
doweling	3/8" x 2'	1
<b>Note:</b> - deck boards must be as straight as possible - cedar is preferred as it is generally straighter, better quality, lighter, rot resistant and easier to work with but will cost much more		

Hardware		
Material	Dimensions	Quantity
deck screws	3" #9	14
deck screws	2" #9	16
carriage bolts	3/8" x 4"	2
locking nuts & washer	3/8"	2
shoulder bolts, Lee Valley Tools #00N14.50	2"	4
flanged insert nuts, Lee Valley Tools #00N10.25	1"	8
threaded eye bolt	1/4" x 2 1/2"	1
screw eyes (large enough for a 10" spike to fit through)		4

## Tools Required

table saw, miter saw, router, drill press, hand drill, jig saw or band saw, 3/8" & 1/2" round and 1/2" by 1" deep straight router bits, 7/16", 5/16", 3/8" and 7/64" drill bits

## Cutting Instructions

If you are making more than one target butt stand a lot of time can be saved by setting up your equipment and cutting all of the same pieces at the same time.

1. Rear Legs (E) - Cut the first 8 ft length of deck board to 79.25". Take the 79.25" board and rip it length ways into two pieces to 2.5" wide for the rear legs. After all of the 2.5" ripping is done, take the 16.75" off cut from the very first cut and rip it to

3.5" wide. This piece will be used to cut the rear leg corner blocks (D) and the flag upright corner blocks (J) from. After all of the ripping is done all of the cut edges should be routed with a 3/8" round bit.

2. Front Legs (A) - Rip the second 8 ft length and the 10 ft length of deck board to 3.5" wide. After all of the 3.5" wide pieces are ripped, reset the saw to 1 5/8" and rip the off cuts to 1 5/8" wide. After all of the ripping is done and before cutting the boards to length all of the cut edges should be routed with a 3/8" round bit.

Cut one front leg (A), 77.25" long, from the 8 ft by 3.5" board and the second front leg (A) from the 10 ft by 3.5" board.

3. The handles (H), 60" long, are cut from the 10 ft by 1 5/8" board.
4. Front (C) and Rear (F) Leg lower cross supports are cut from the 8 ft by 1 5/8" board. Note that these pieces have 7° angle cuts on the ends (see diagram 2).
5. Front Legs Top is cut from the remainder of the 3.5" by 10 ft board. Note that this piece has 7° angle cuts on the ends (see diagram 2). The front leg corner blocks (D) are also cut from this piece.
6. Flag / Number Upright (I) is cut from the remainder of the 3.5" by 8 ft board. The space blocks (G) are cut from the remainder.

### **Routing Instructions**

1. As noted in the cutting instructions, all of the long cut edges should be round off to be the same as the uncut long edges using a 3/8" round router bit. It is best if this is done on the long ripped pieces before they are cut up into individual pieces.
2. As well as the long edges the tops of the legs should also be routed with the 3/8" round bit.
3. The last 6" on each end of the handles (H) should be routed with a 1/2" round router bit to make a hand grip area. These should also be sanded.
4. The round tops of the rear legs can be made using either a hand jig saw or a band saw. For making large numbers of butts, it was found to be faster to create a template of the rounded end on the band saw and use a straight bit with a ball bearing guide against the template to cut the rounded ends.

### **Drilling Instructions**

All holes should be drilled with a drill press as they have to be perfectly straight. For large number of butts, 1/4" thick metal drill templates can be made up and a hand drill used. This was done for the 50 butts made for the 2004 Canadian Championships. Hole locations are given in Diagrams 3 and 4 and in the table below. Unless otherwise stated all holes go right through the wood.

Hole Size and Locations			
Piece	Hole Size	Distance From Top	Distance From Side
Front legs (A)	7/16"	2 1/2"	1"
	5/16"	23 5/8"	1"
		25 3/4"	1"
		27 1/4"	1"
		* 31 1/2"	1"
	7/64"	1"	1"
		1"	2 1/2"
		2 1/2"	2 3/4"
		4 1/2"	2 3/4"
		* 30 1/4"	2 3/4"
		* 29 1/4"	2 3/4"
		* 2"	1 3/4"
	* - distance from bottom		
	Front legs Top (B)	7/16"	3/4"
3/4"			3"
1 3/4"			3"
1 3/4"			25.5"
3/4"			25.5"
3/4"			27.5"
1" (ends)			1/2"
2" (ends)			1/2"
5/16"		1 3/4"	14.25"
Front legs lower cross (C)	7/16"	5/16" (both ends)	1/2" - 2" deep
		1 5/16" (both ends)	1/2" - 2" deep
Front legs corner blocks (D)	7/16"	1"	1/2" - 1" deep
		3"	1/2" - 1" deep
Rear legs (F)	7/16"	1 1/4"	1 1/2"
	5/16"	50 7/8"	1 1/2"
		52 7/8"	1 1/2"
		54 5/8"	1 1/2"
	7/64"	58"	1"
		58"	2"
		59 1/4"	1 1/2"
61 1/4"		1 1/2"	

Hole Size and Locations			
Piece	Hole Size	Distance From Top	Distance From Side
rear legs lower cross (F)	7/64"	1"	centre
		3"	centre
		35 7/8"	centre
		37 7/8"	centre
		5/16" (both ends)	1/2" - 2" deep
		1 5/16" (both ends)	1/2" - 2" deep
spacer block (G)	7/16"	centre	centre
Handles (H)	5/16"	19 1/8"	13/16"
		44"	13/16"
		47 3/4"	13/16"
		52 3/8"	13/16"
	3/8"	8 7/8"	1/2"
flag/number support (I)	3/8"	1 3/4"	1/2" - 2" deep
	5/16"	1 3/4"	1/2" - 2" deep

## Assembly

### Front Legs

- attach the two front legs (A) to the top (B) using 3" deck screws.
- attach the front lower cross support (C) to the two legs using 3" deck screws.
- attach the two corner blocks (D) to the top and legs using 2" deck screws.

### Rear Legs

- attach the two rear legs (E) to the rear lower cross support (F) using 3" deck screws
- attach the two corner blocks (D) to the legs and cross support using 2" deck screws. If you are using a power drill to drive the screws you will need a long bit to drive the screw through the cross support closest to the leg .

### Handles

- insert the flanged insert nuts into the handles using a 6 mm hex wrench. When doing a large number of these a 6 mm hex bit for a hand drill works well. The nuts are inserted until the shoulder of the nut is flush with the wood.

Note: there is a left and right handle. This is determined by the 3/8" hole on the top of the handle into which a 2" piece of doweling is inserted. On the right hand handle, with the 3/8" hole facing up, the nut closest to the 3/8" hole goes in the right side and the other 3 nuts go in the left side. The left handle is the opposite.

### Final Assembly

- the front legs are placed with the front down and the rear legs are placed inside.
- the spacer blocks (H) are placed between the front and rear legs at the top and the 3/8" carriage bolt run through the front leg, spacer block and then rear leg.

- A washer and locking nut are added and tighten.
- the handles are attached to the rear legs with the 2" shoulder bolts with the bolt going through the leg and into the insert nut in the handle.
  - in the storage position the handle is folded up and the legs folded together. The front leg shoulder bolt goes through one of the three 5/16" holes in the front leg into the insert nut in the handle
  - insert two screw eyes into the front legs in the two lower holes
  - insert two screw eyes into the front leg top (B) located near each leg. A string is tied between these two eyes a looped to the top of the foam butt and secured with a target pin in the butt to keep it from toppling forward in a wind.
  - attach the two corner blocks to the number upright piece using nails or screw, making sure not to go through the 5/15" hole. Then drive an insert nut into the 5/16" hole. The 1/4" x 2 1/2" threaded eye bolt goes through the centre hole in the front leg top (B) up into the insert bolt in the flag/number upright (I) and tightened. This is used to attach the rear tie down rope to. If you are not using the flag/number upright the rope can go through the 5/16" hole in (B).

If you have any questions about the building of the Archers of Caledon Outdoor Target Butt Stand please contact Randall Jones at "rjones0216@rogers.com".

# The Archers of Caledon

## Outdoor Target Butt Stand

### Diagram 1: Cutting Diagram

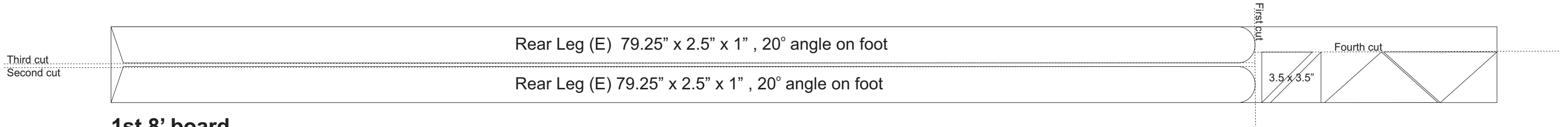

#### 1st 8' board

- first cut board to 79.25" long.
- rip two Rear Legs (E) pieces 2.5" wide from the 79.25"
- rip end cut to 3.5" wide and then cut two Corner Block (D) and 2 Flag Corner Blocks (J) pieces from this piece.

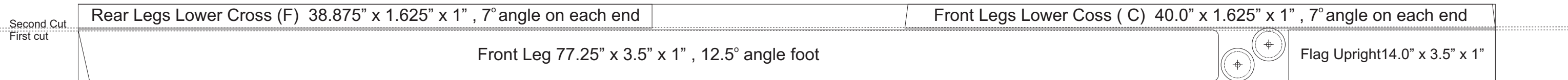

#### 2nd 8' board

- 1st rip 3.5" wide full length of board
- 2nd trim left over piece to 1 5/8" wide
- next cut one Front Leg (A), two 2.25" Circles (G), and Flag Upright (I) piece from 3.5" board
- next cut Front (C) and Rear (F) leg lower cross supports from 1 5/8" board.

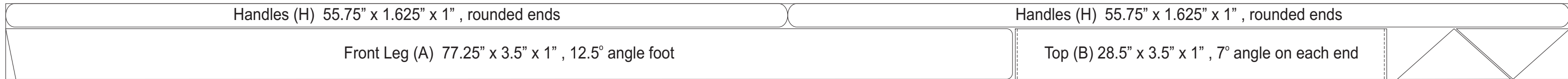

#### 10' board

- 1st rip 3.5" wide full length of board
- 2nd trim left over piece to 1 5/8" wide
- next cut one Front Leg (A), Front Leg Top (B) piece, and two Corner Blocks (D) from 3.5" board
- next cut two Handles (H) from 1 5/8" board

**All cut edges on legs, handles, lower cross supports, top and flag pieces should be routed with 3/8" round bit.**

# Diagram 2:

# The Archers of Caledon Outdoor Target Butt Stand

Front Leg (A)

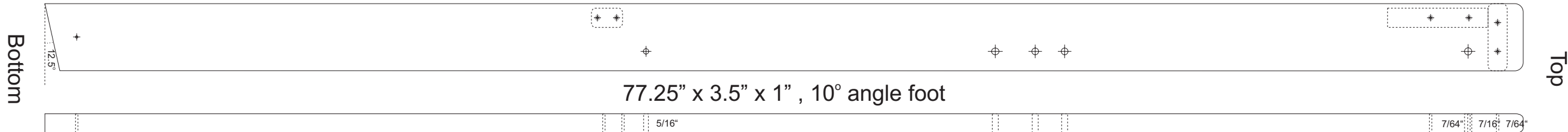

Front Legs Lower Cross Support ( C )

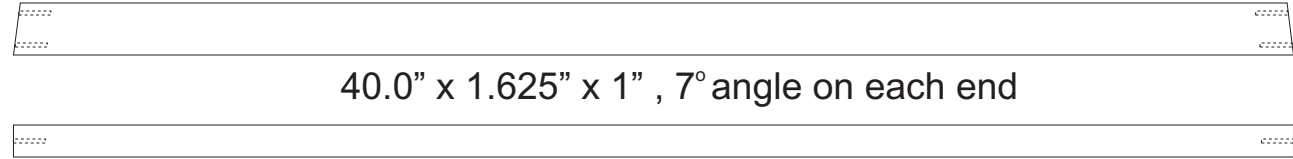

Front Legs Top ( B )

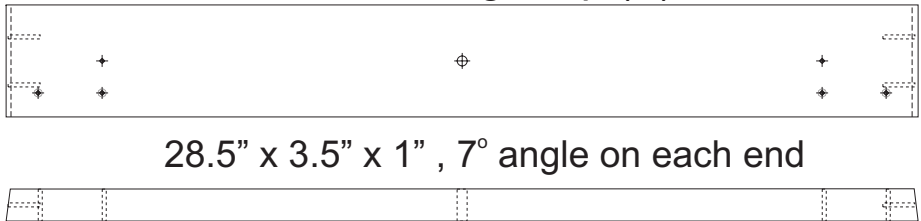

Front Legs  
Top Corner Block ( D )

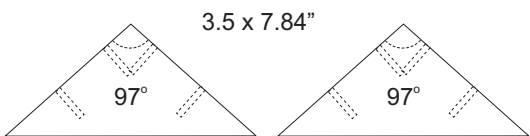

Rear Leg (E)

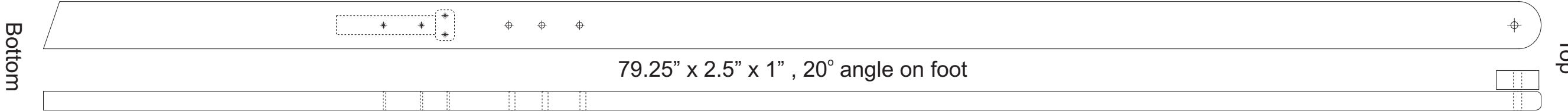

Rear Legs Lower Cross Support ( F )

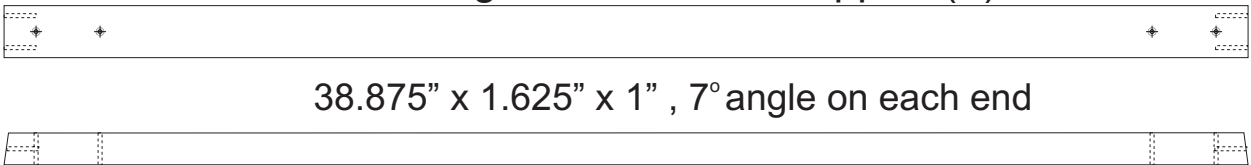

Rear Legs  
Lower Corner Block ( D )

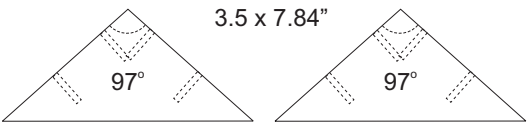

Spacer Block ( G )

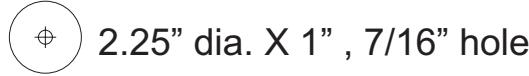

Handle ( H )

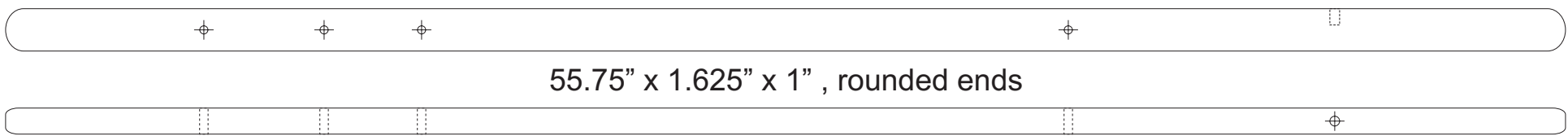

Number & Flag Stand ( I & J )

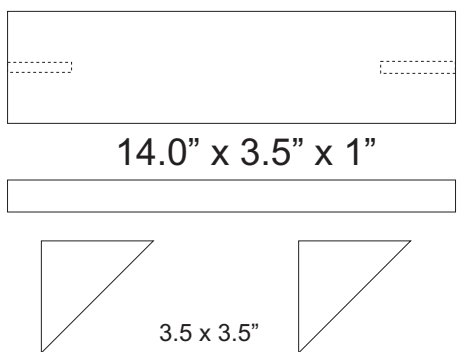



# Diagram 3: Hole Sizes and Locations

# The Archers of Caledon Outdoor Target Butt Stand

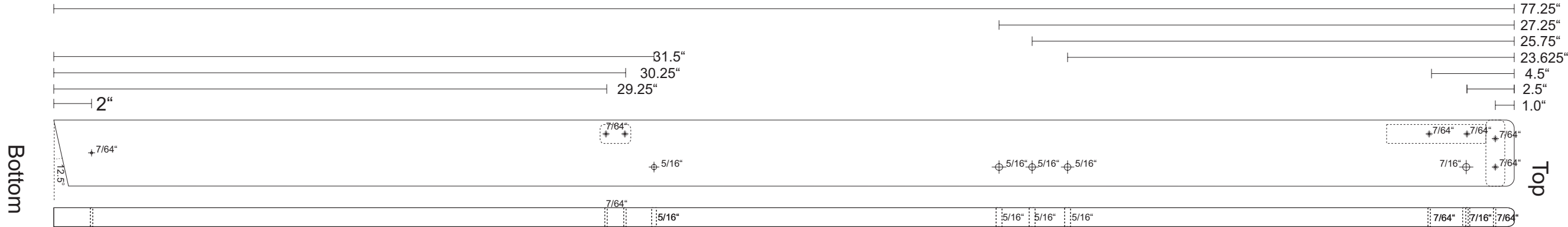

**Front Leg (A)** 77.25" x 3.5" x 1" , 12.5° angle foot,

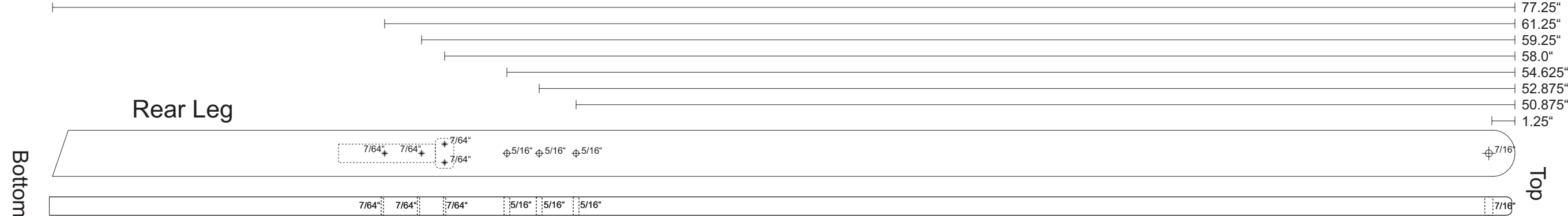

**Rear Leg (E)** 79.25" x 2.5" x 1" , 20° angle on foot

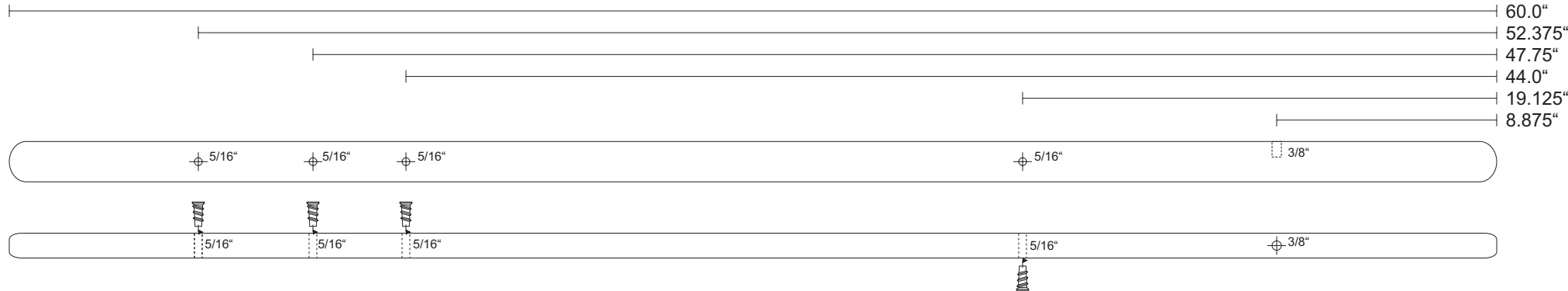

**Handle (H)** 55.75" x 1.625" x 1" , rounded ends

# Diagram 4: Hole Sizes and Locations

# The Archers of Caledon Outdoor Target Butt Stand

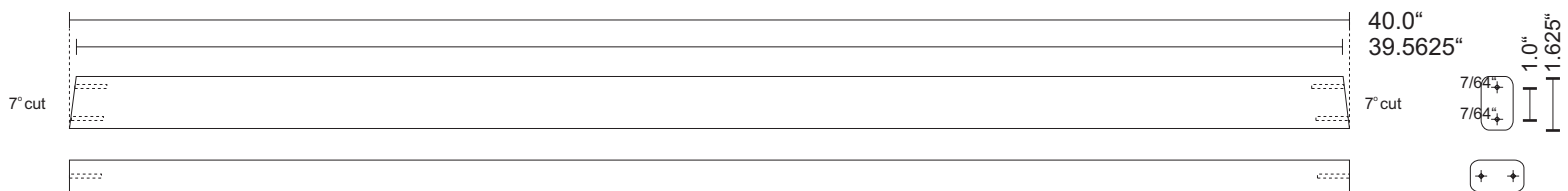

**Front Legs Lower Cross Support ( C ) 40.0" x 1.625" x 1" , 7° angle on each end**

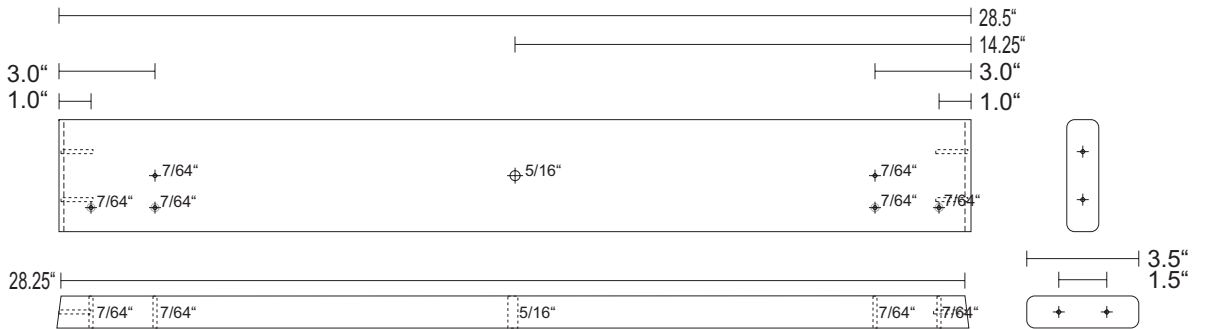

**Front Legs Top (B) 28.5" x 3.5" x 1" , 7° angle on each end**

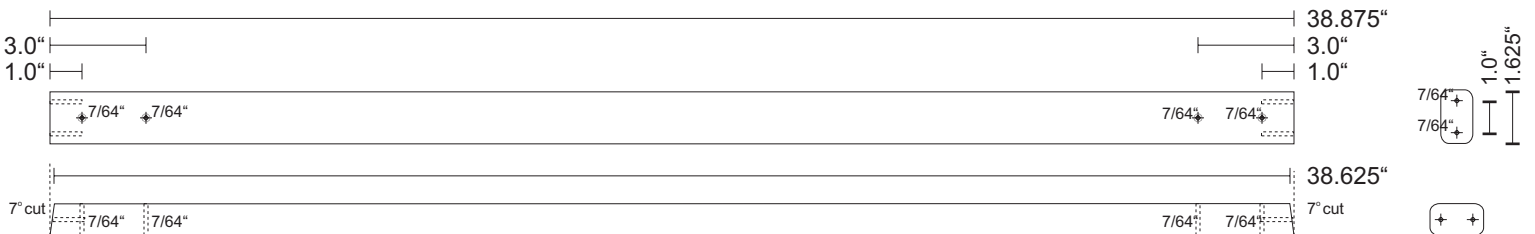

**Rear Legs Lower Cross Support (F) 38.875" x 1.625" x 1" , 7° angle on each end**

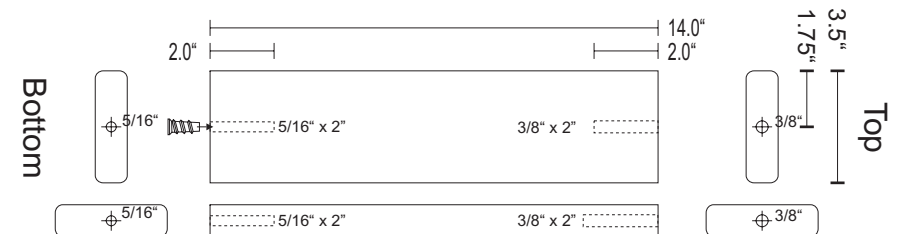

**Number & Flag Stand (I) 14.0" x 3.5" x 1"**

**Front & Rear Legs  
Corner Block (D)**

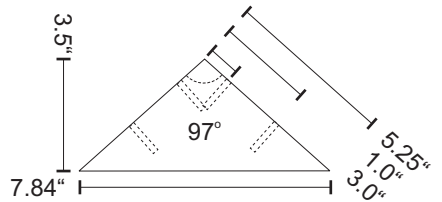

**Spacer Block (G)**



**Number & Flag Stand  
Corner Blocks (I)**

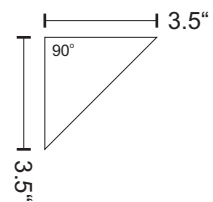

# Diagram 5: Side View

with read leg in 10, 12.5 and 15 degree positions

# The Archers of Caledon Outdoor Target Butt Stand

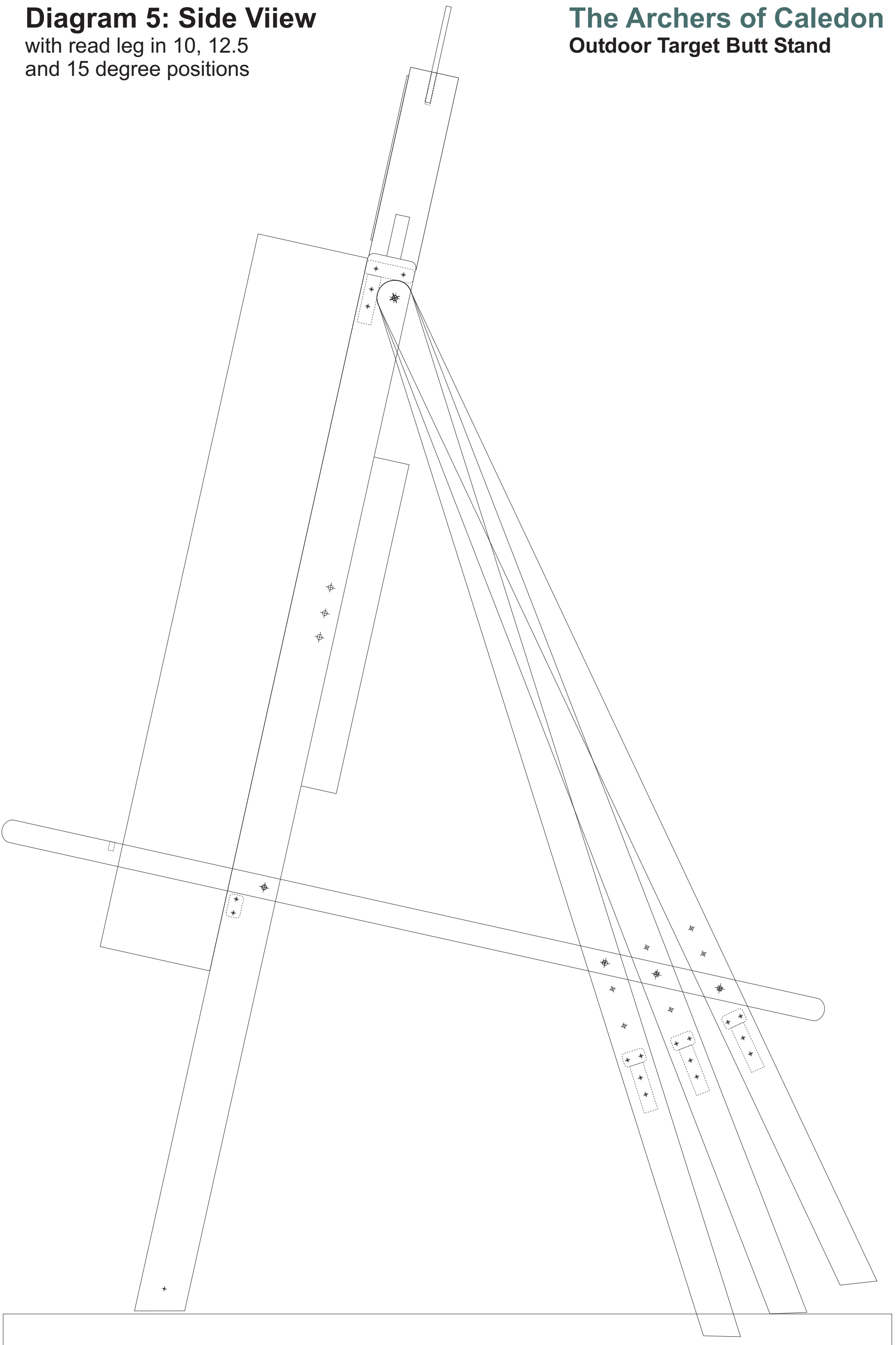

# Diagram 6: Front View

# The Archers of Caledon Outdoor Target Butt Stand

